

ASSEMBLING INSTRUCTION

COMPONENTS

MARTIN[®] SERIES

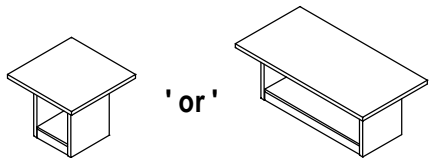

'or'

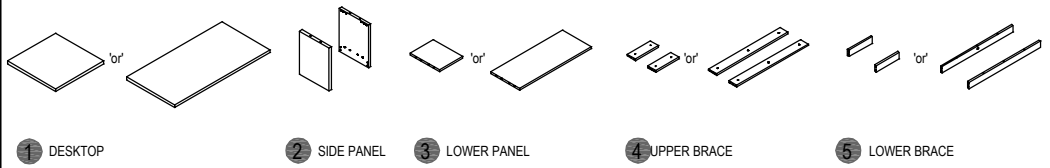

OCCASIONAL TABLE

FORMCASE[®]
FORMING A BETTER WORKPLACE
www.formcase.com

HARDWARE

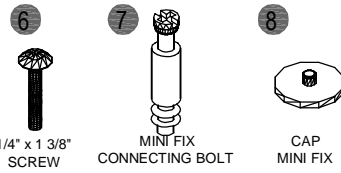

TOOL REQUIRED :
- PHILLIPS HEAD SCREW DRIVER AND FLAT HEAD SCREW DRIVER

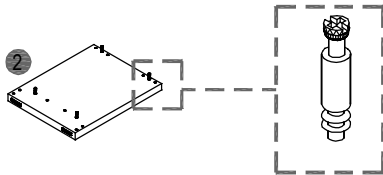

Step 1
Attach the mini fix connecting bolt into the nylon sockets provided in each panel.

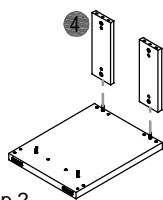

Step 2
a. Attach the upper brace into side panel.
b. Tighten all mini fix housings.

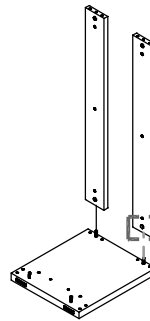

Attach to the all mini fix housings

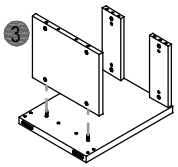

Step 3
a. Attach the lower panel to the pre-assembled components and tighten all mini fix housings.

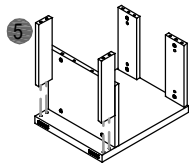

b. Attach the lower brace into side panel.

'or'

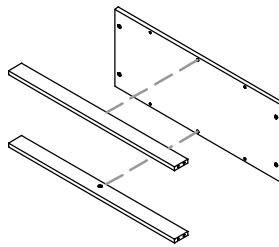

Step 3
a. Attach the lower brace into lower panel and Tighten all mini fix housings.

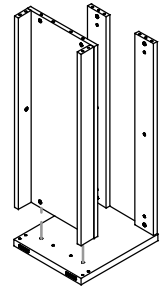

b. Attach the lower brace and lower panel to the pre-assembled components and tighten all mini fix housings.

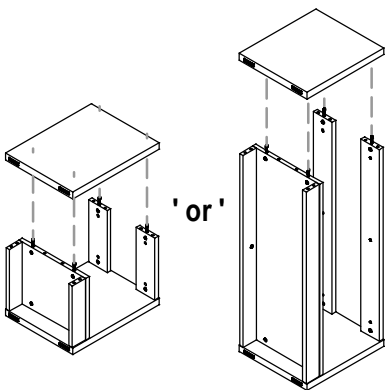

'or'

Step 4
Attach the another side panel to the pre-assembled components and tighten all mini fix housings.

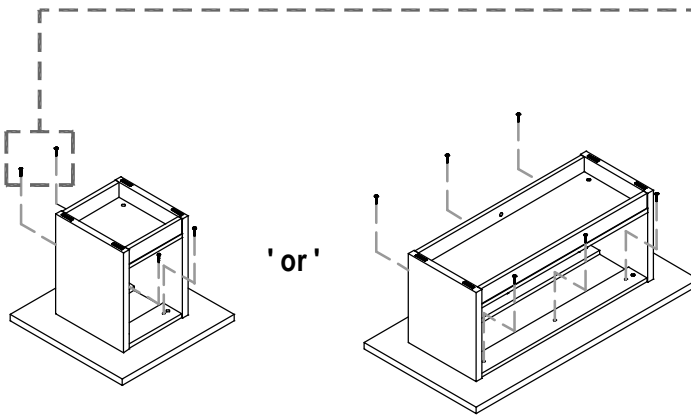

'or'

Step 5
a. Put the pre-assembled componet on the table top.
b. Attach the table base drum to the table top by using 1/4" x 1 3/8" screws.(See detail 1)

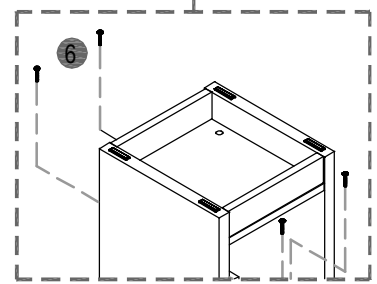

Detail 1

