

# ASSEMBLING INSTRUCTION

# COMPONENTS

## MARTIN<sup>®</sup> SERIES

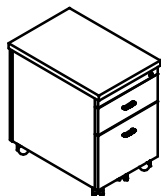

### MOBILE PEDESTAL

**FORMCASE<sup>®</sup>**  
FORMING A BETTER WORKPLACE  
www.formcase.com

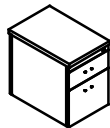

1 PEDESTAL

## HARDWARE

2



1/4" x 1 3/8" SCREW

3



1/8" x 1 1/2" SCREW

4



1/4" x 5/8" WOOD SCREW

5



FLAT BRACKET

6

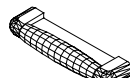

PULL(for drawer)

7



CASTER

#### TOOL REQUIRED :

- PHILLIPS HEAD SCREW DRIVER AND FLAT HEAD SCREW DRIVER
- WRENCH 1/2 "

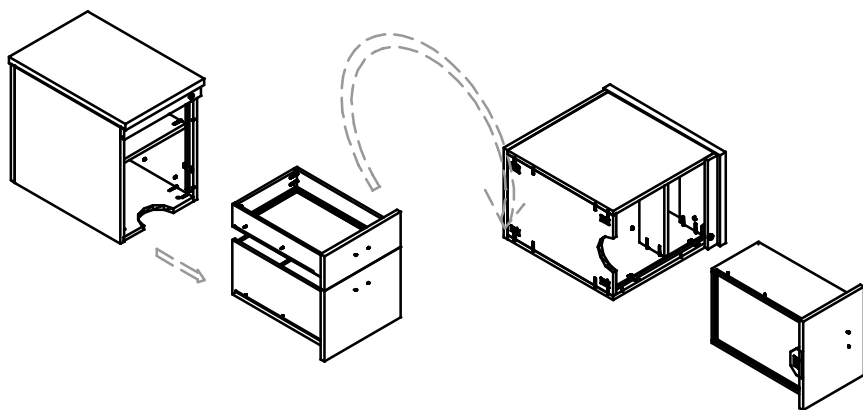

#### Step 1

- Remove all drawers from body.
- Rotate 90° the body on the soft carpet(recommended) for installing casters.

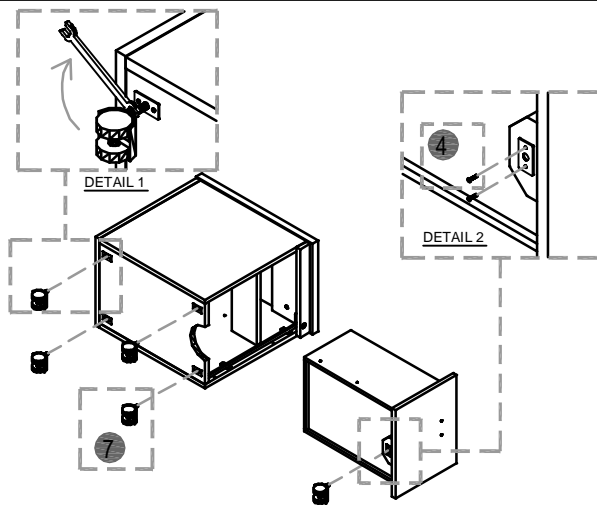

#### Step 2

- Attach the casters into the lower panel by using wrench 1/2".(see detail 1)
- use 1/4" x 5/8" screws to attach flat bracket to the drawer.(see detail 2)

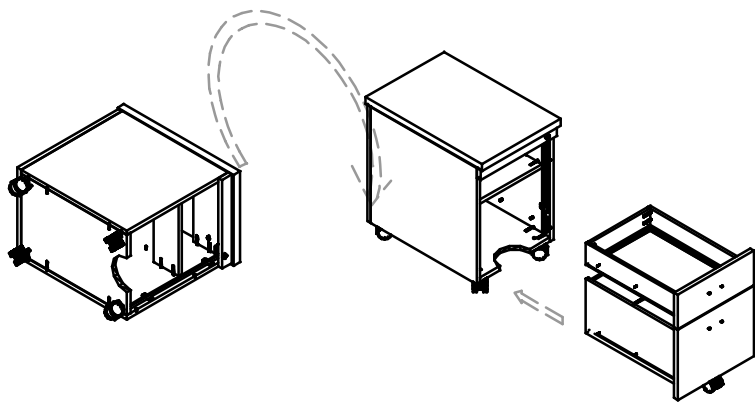

#### STEP 3

- Rotate 90° all components.
- Insert all drawers to the body.

#### STEP 4

For installing all handles please see installing drawers instruction below.

#### INSTALLING HANDLES

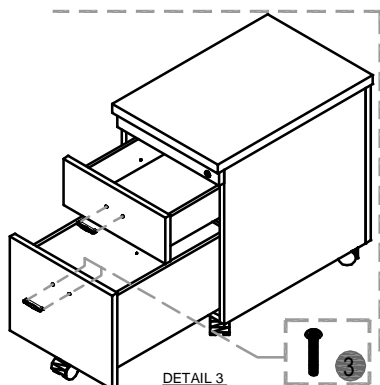

#### Step 4

Attach the pulls to the drawers by using 1/8" x 1 1/2" screws.(see detail 3)